

Table of Contents

Table of Contents	2
Introduction	3
Product Inspection	5
The DPAC-CAM-250 Device Care and Handling Precautions.....	6
General DPAC-CAM-250 device, TPA, Cable, and Connector Care and Handling.....	8
Handling and Storage	8
Visual Inspection	8
Cleaning	8
Making Connections.....	8
Electrostatic Discharge Information.....	9
Mechanical and Environmental Specifications.....	10
User Models.....	12
DPAC-CAM-250 User Interface Software	15
Introduction	15
DPAC-CAM-250 LED Status Indicators.....	15
DPAC-CAM-250 Device Supported USB Type-C Functions	16
DPAC-CAM-250 Software File List.....	17
Installation	17
DPAC-CAM-250 UI PC Program Operation	18
DPAC-CAM-250 UI / API Connection to DPAC-CAM-250 Hardware.....	18
DPAC-CAM-250 Device TI Type-C Configuration ROM Select.....	19
Set USB Type-C Port Configuration (Lane Flip)	19
Select DUT Type for Configuration Flip	20
LFPS Pinging (USB Only).....	20
DisplayPort Handshake Messages (DisplayPort Alt Mode Only)	20
DisplayPort Receiver (DPRx) Control.....	21
DPAC-CAM-250 Application Program Interface (API)	22
Wilder Technologies, LLC – Limited Warranty.....	23
Wilder Technologies, LLC – Terms & Conditions of Sale	24
Compliance with Environmental Legislation	25
WEEE Compliance Statement	25
Compliance to RoHS 2 Substance Restrictions	25
Glossary of Terms.....	26

Introduction

This user’s manual documents the DisplayPort Aux Controller with Type-C Alternate Mode Control (hereafter, DPAC-CAM). When used in conjunction with Wilder Technologies Type-C Test Adapters (TYPE-C-TPA-P and TYPE-C-TPA-R), the user can select either DisplayPort Type-C (Alt Mode), USB Type-C (Native Mode), or Thunderbolt Type-C (Alt Mode) operational modes via Control Software.

The DPAC-CAM-250 device enables compliance testing of USB, Thunderbolt, and DisplayPort

- USB (Native)
 - Supports LFPS Pinging for USB compliance testing.
- Thunderbolt Alt Mode
 - Can support Thunderbolt testing with the use of Wilders Thunderbolt Generation 2 Microcontroller (TBT-TPA-UHG2).
- DisplayPort Alt Mode
 - Built in DisplayPort Receiver to enable source DUT compliance patterns.
 - Adjustable AUX amplitude settings for AUX sensitivity testing.
 - Also works for Legacy DisplayPort and Mini DisplayPort DUTs.

The DPAC-CAM-250 device, shown in Figures 1 and 2, when used with the DPAC-CAM-250 device Control Software allows the user to remotely (via PC) control the Type-C operational mode, eliminating the need to manually set switches or adjust jumper positions, sometimes seen on other test adapters or control modules. Testing DisplayPort, USB, and Thunderbolt Type-C interface cables, hosts and devices against the DisplayPort, USB, and Thunderbolt Type-C Standards and Compliance Specifications is facilitated with the use of the DPAC-CAM-250 device and Control Software.

NOTE: To avoid damaging the DPAC-CAM-250 device, test adapters or accessory cables, use the handling techniques described in the Care and Handling section before making any connections or configuring a test setup.

Always use a static-safe workstation when performing tests, as explained in the “Electrostatic Discharge Information” section.

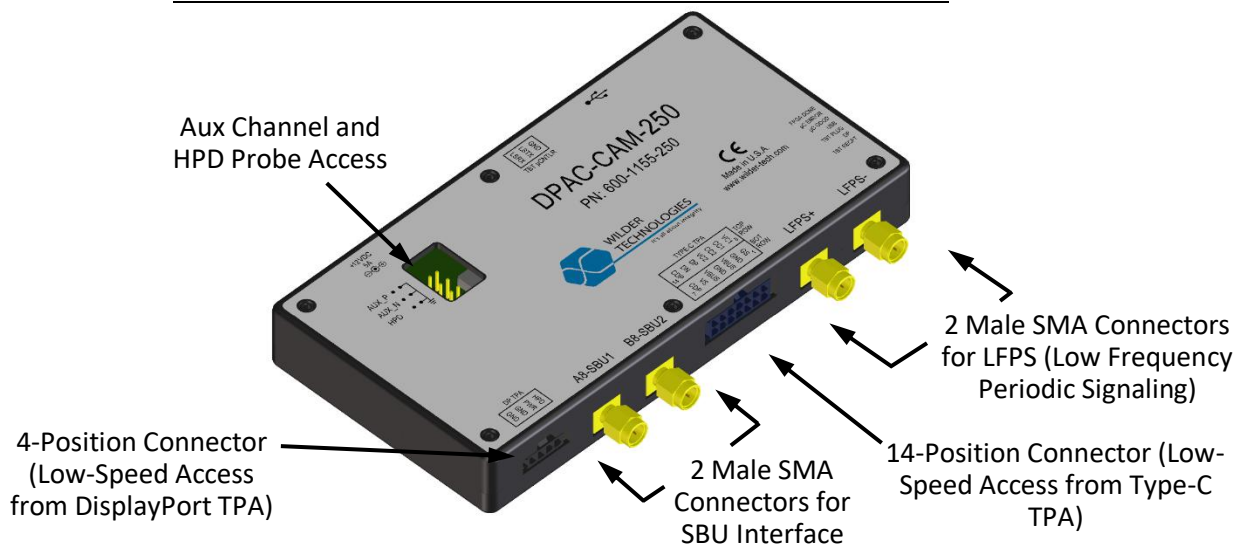

Figure 1. The DPAC-CAM-250 Mode Control Module (Front-Top View).

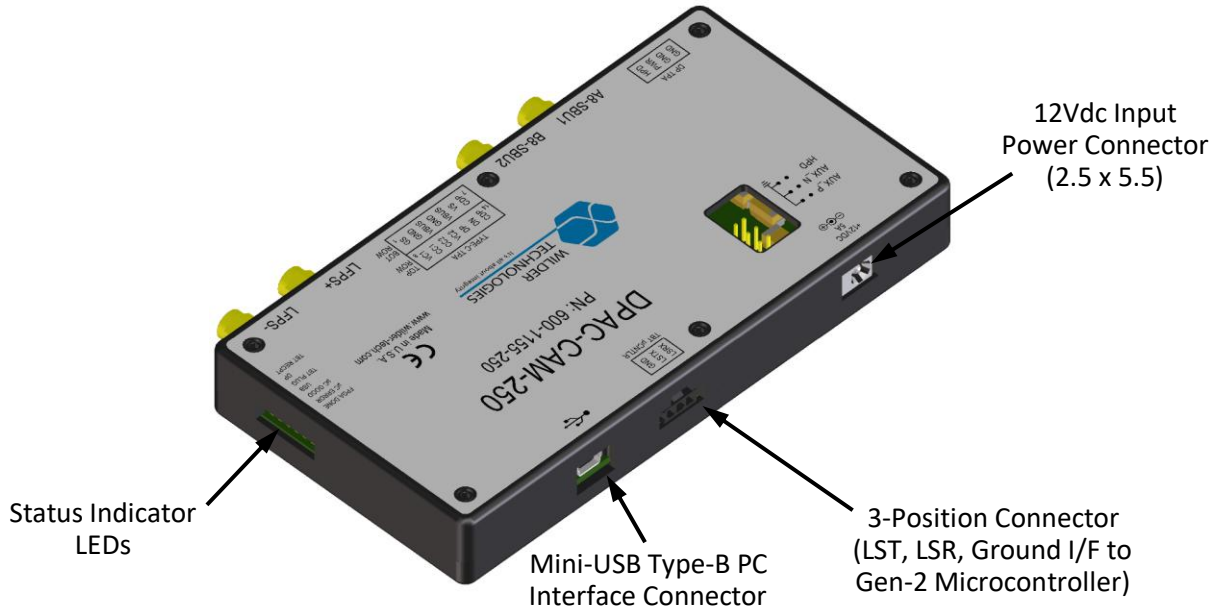

Figure 2. The DPAC-CAM-250 Device (Back-Top View).

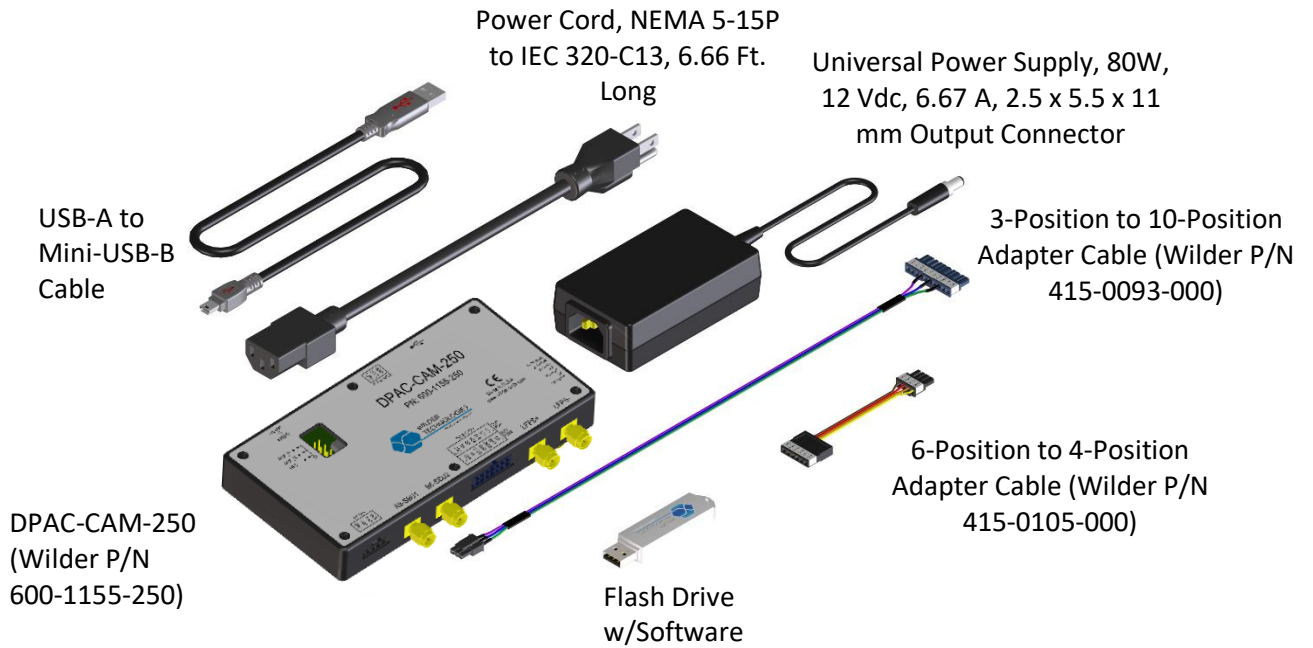

Figure 3. DPAC-CAM-250 Included Items

The above figure illustrates the components included with the DPAC-CAM-250 product. Refer to the TYPE-C-TPA Test Adapter and the TBT-TPA-UHG2 Gen-2 Microcontroller Module User Manuals for components included with those products.

Product Inspection

Upon receiving the DPAC-CAM-250 device from Wilder Technologies, perform the following product inspection:

- Inspect the outer shipping container, foam-lined instrument case, and product for damage. Retain the outer cardboard shipping container until the contents of the shipment have been inspected for completeness and the product has been checked mechanically and electrically. Use the foam-lined instrument-case for secure storage of the Wilder Technologies DPAC-CAM-250 device when not in use.
- Locate the shipping list and verify that all items ordered were received.
- In the unlikely event that the product is defective or incomplete, the “Limited Warranty” section discusses how to contact Wilder Technologies for technical assistance and/or how to package the product for return.

The DPAC-CAM-250 Device Care and Handling Precautions

The DPAC-CAM-250 device, mating Type-C Test Adapters, and the mating Gen-2 Microcontroller all require careful handling to avoid damage. To achieve optimum performance and to prolong the product life, observe the following handling precautions:

- **CAUTION 1: Avoid Torque Forces (Twisting)**
While individual coaxial cables (as used on Type-C TPAs) connected to the DPAC-CAM-250 device have some rotational freedom, twisting an attached TPA as a unit, with one end held stationary, may damage or severely degrade performance. Adherence to Caution 5 (below) helps to avoid twisting.
- **CAUTION 2: Avoid Sharp Cable Bends (Type-C TPAs)**
Never bend coaxial cables into a radius of 26 mm (1-inch) or less. Never bend cables greater than 90°. Single or multiple cable bends must be kept within this limit. Bending coaxial cables connected to the DPAC-CAM-250 device cables less than a 26mm (1-Inch) radius will permanently damage or severely degrade the attached test adapter performance.
- **CAUTION 3: Avoid Cable Tension (Type-C TPAs)**
Never apply tension (pull forces) to an individual coaxial cable that is greater than 2.3 kg (5 lbs.). To avoid applying tension, always place accessories and equipment on a surface that allows adjustment to eliminate tension on Type-C TPAs and cables. Use adjustable elevation stands or apparatus to accurately place and support both the DPAC-CAM-250 device and the attached Type-C Test Adapter.
- **CAUTION 4: Connect the Type-C TPA to the DUT First**
To prevent twisting, bending, or applying tension to coaxial cables when connecting a Type-C TPA to the DUT, always attach the Type-C TPA to the device under test (DUT) or cable under test before attaching to the DPAC-CAM-250 device, and/or test instrumentation.

If the Type-C TPA must be turned or twisted to make connection to the DUT, avoid using the Type-C TPA housing alone to make this occur. Try to distribute the torque forces along the length of the test setup and connected cabling. If this is not possible, it is recommended to first loosen or disconnect the connections at the Type-C TPA and/or DPAC-CAM-250 device. Make the connection to the DUT and then re-attach to the DPAC-CAM-250 device and/or the test equipment leads.

NOTE: Only grip the test adapter housing when inserting or extracting the Type-C TPA to or from the DPAC-CAM-250 device. Pulling directly on the Type-C TPA cables or using them to insert the Type-C TPA may cause damage.

- **CAUTION 5: Carefully Make SMA Connections** (Type-C TPAs to DPAC-CAM-250 device)
To connect the Type-C TPA SMA connectors, follow these steps:

1. Hold the cable stationary by grasping the cable at the black heat-shrink section near the SMA connector.
2. Insert the mating SMA barrel and hand-tighten the free-spinning nut onto the connector while avoiding pulling, bending, or twisting the Type-C TPA coaxial cable.
3. The Type-C TPA SMA connectors have flats that accept an open-end 1/4-inch or 6.5mm wrench. When attaching instrument cables to the Type-C TPA, it is recommended that the Type-C SMA connectors be mechanically held and the test leads be tightened to the equipment manufacturer's torque recommendations, normally 8 lb-in., using a 5/16-inch open-end wrench.

If the test set-up requires repositioning, first loosen or disconnect the SMA connections to avoid twisting, bending, or tension.

NOTE: A drop in signal amplitude by half or 6 dB during the testing of a channel may indicate that a cable has been mechanically pulled free of the coaxial cable connections within the test adapter assembly. This could be determined by checking if the coaxial cable has any play relative to the TPA. This would only occur when the TPA has exceeded the pull force as specified within the mechanical specification. If the cable cannot be re-seated, the test adapter may need to be returned to the factory for service.

- **CAUTION 6: Independently Support Instrument Cables or Accessories**
Excessive weight from instrument cables and/or accessories connected to the DPAC-CAM-250 device or Type-C TPA can cause damage or affect the test adapter performance. Be sure to provide appropriate means to support and stabilize all test set-up components.

General DPAC-CAM-250 device, TPA, Cable, and Connector Care and Handling

Observing simple precautions can ensure accurate and reliable measurements.

Handling and Storage

Before each use of the DPAC-CAM-250 device, ensure that all connectors are clean. Handle all cables carefully and store the DPAC-CAM-250 device in the foam-lined instrument case when not in use, if possible. Do not set connectors contact-end down. Install the protective end caps onto the SMA connectors when the DPAC-CAM-250 device is not in use.

Visual Inspection

Be sure to inspect all cables carefully before making a connection. Inspect all cables for metal particles, scratches, deformed threads, dents, or bent, broken, or misaligned center conductors. Do not use damaged cables.

Cleaning

If necessary, clean the connectors using low-pressure (less than 60 PSI) compressed air or nitrogen with an effective oil-vapor filter and condensation trap. Clean the cable threads, if necessary, using a lint-free swab or cleaning cloth moistened with isopropyl alcohol. Always completely dry a connector before use. Do not use abrasives to clean the connectors. Re-inspect connectors, making sure no particles or residue remains.

Making Connections

Before making any connections, review the “Care and Handling Precautions” section. Follow these guidelines when making connections:

- Align cables (instrument or Type-C TPA) carefully
- Make preliminary connection lightly
- To tighten SMA connectors, turn the connector nut on the DPAC-CAM-250 device only
- Do not apply bending force to cables (instrument or Type-C TPA)
- Do not over-tighten preliminary connections
- Do not twist or screw-in cables
- Use an appropriately sized torque wrench (depends on SMA connector gender), and do not tighten past the “break” point of the torque wrench (normally set to 8 lb-in.)

Electrostatic Discharge Information

Protection against electrostatic discharge (ESD) is essential while connecting, inspecting, or cleaning the DPAC-CAM-250 device and/or Type-C test adapters and connectors attached to a static-sensitive circuit (such as those found in test sets).

Electrostatic discharge can damage or destroy electronic components. Be sure to perform all work on electronic assemblies at a static-safe work station, using two types of ESD protection:

- Conductive table-mat and wrist-strap combination
- Conductive floor-mat and heel-strap combination

When used together, both of these types provide a significant level of ESD protection. Used alone, the table-mat and wrist-strap combination provide adequate ESD protection. To ensure user safety, the static-safe accessories must provide at least 1 M Ω of isolation from ground. Acceptable ESD accessories may be purchased from a local supplier.

The DPAC-CAM-250 device should always be stored within the provided static-dissipative shield bag and sealed when not in use.

WARNING: These techniques for a static-safe work station should not be used when working on circuitry with a voltage potential greater than 500 volts.

Mechanical and Environmental Specifications

NOTE: All specifications in this manual are subject to change.

Table 1. General Specifications

ITEM	DESCRIPTION
Usage Environment	Controlled indoor environment
DPAC-CAM-250 Device	3.16 x 6.04 x 0.875 Inches (80.3 x 153.4 x 22.2mm)
Operating Temperature	0°C to +55°C (32°F to +131°F) (Characteristic)
Storage Temperature	-40°C to +70°C (-40°F to +158°F) (Characteristic)

DPAC-CAM-250 Device Pin-out

The DPAC-CAM-250 Device provides two male SMA connectors for SBU-1 and SBU-2 interface to/from a Type-C TPA. A 14-position connector provides other, low-speed signal interface to/from a Type-C TPA, and a 4-position connector provides low-speed signal interface to/from a DisplayPort or Mini DisplayPort TPA. LSTX and LSRX signals (for Gen-2 Microcontroller interface) are accessed through one 3-position low-speed connector. A USB Mini-USB Type-B is provided for the PC User Interface. The LFPS (Low Frequency Periodic Signaling) is accessed through 2 Male SMA connectors. All connectors are identified by labels. The following figure refers to pin-description tables for each of the connector types.

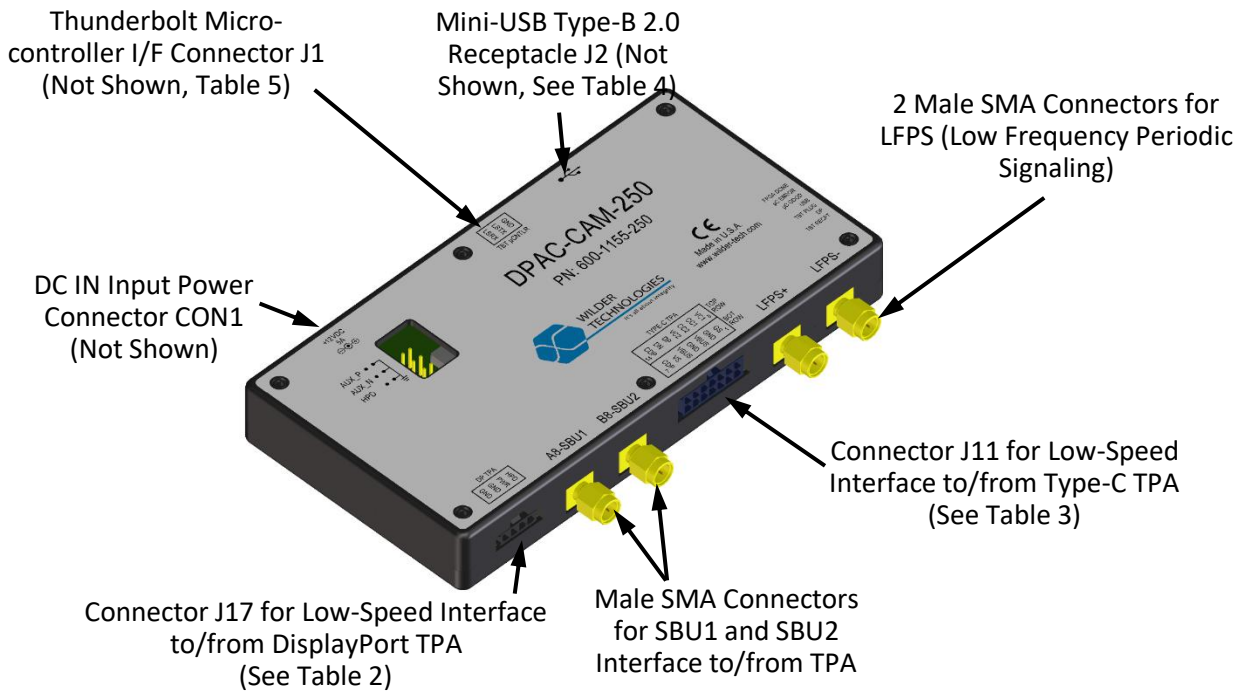

Figure 4. DPAC-CAM-250 Device Connectors

Table 2. DisplayPort Low-Speed Connector (J17) Pin Assignments (DisplayPort Only)

Pin Description	Connector Pin Number
Hot Plug Detect	1
DP_PWR	2
Ground	3
Ground	4

Table 3. Type-C Low-Speed Connector (J11) Pin Assignments (Thunderbolt Only)

Pin Description	Connector Pin Number(s)
Ground Sense	1
Ground	2
VBUS	3
Ground	4
VBUS	5
VS	6
CDP	7
VC1	8
CC1	9
CC2	10
VC2	11
DP	12
DN	13
CDP	14

Table 4. Mini-USB Type-B 2.0 Receptacle Connector (J2) Pin Assignments (PC User Interface)

Pin Description	Connector Pin Number(s)
Vbus (5V)	1
D-	2
D+	3
ID (No Connect)	4
Ground	5

Table 5. Thunderbolt Microcontroller Connector (J1) Pin Assignments

Pin Description	Connector Number
LSRX	1
LSTX	2
Ground	3

User Models

The DPAC-CAM-250 device, when used in conjunction with a Type-C TPA, is capable of performing within the scope of measurements contained in the associated CTS PHYs, limited only by the specifications, environmental, care and handling as stated in this document.

The following examples are suggestions and/or references for possible testing setups.

This first example illustrates a Thunderbolt Type-C Host/Device test using a DPAC-CAM-250 and Type-C Plug TPA connected to Thunderbolt Gen 2 Microcontroller. The Type-C Plug TPA connections are made to the DPAC-CAM-250 device through the A8 cable, B8 cable, and 14-position low speed cable.

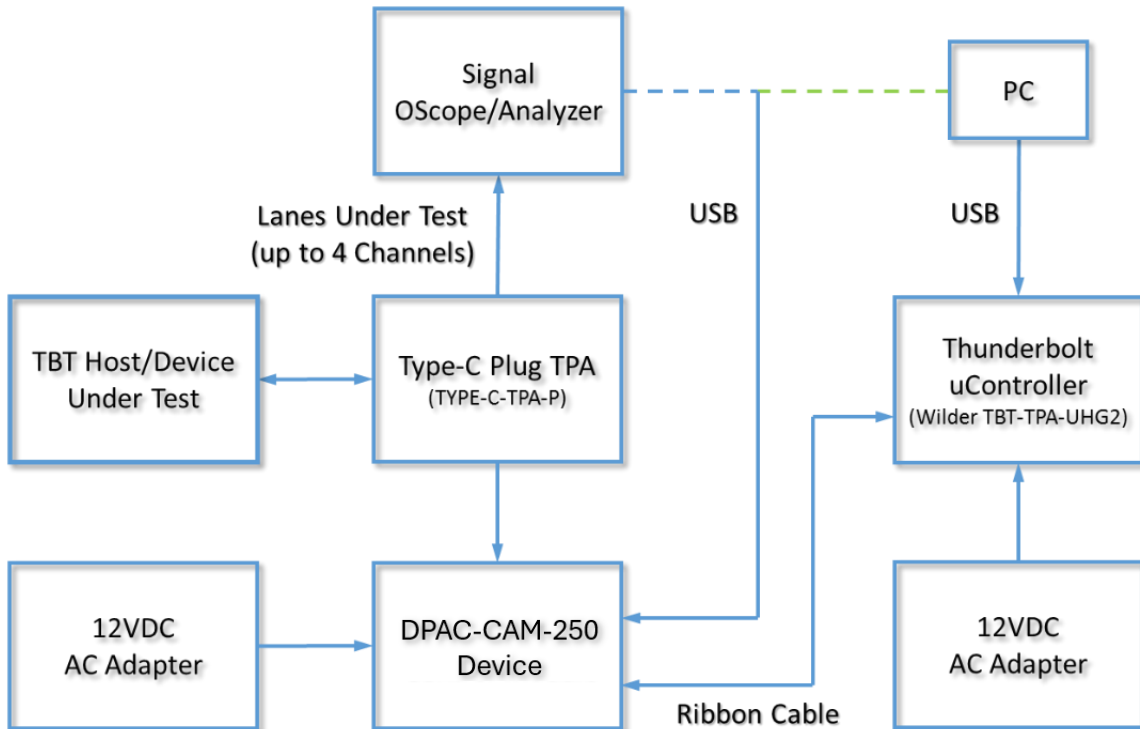

This second example illustrates a DisplayPort Type-C Host/Device test using a DPAC-CAM-250 device and Type-C Plug TPA connected to a DisplayPort AUX Controller and a Signal Oscilloscope/Analyzer. The Type-C Plug TPA connections are made to the DPAC-CAM-250 through the A8 cable, B8 cable, and 14-position low speed cable. The DisplayPort/ Mini DisplayPort Plug TPA is connections are made to the DPAC-CAM-250 device by AUX_P cable to A8 SMA, AUX_N cable to B8 SMA, and low speed cable to 4-position connector.

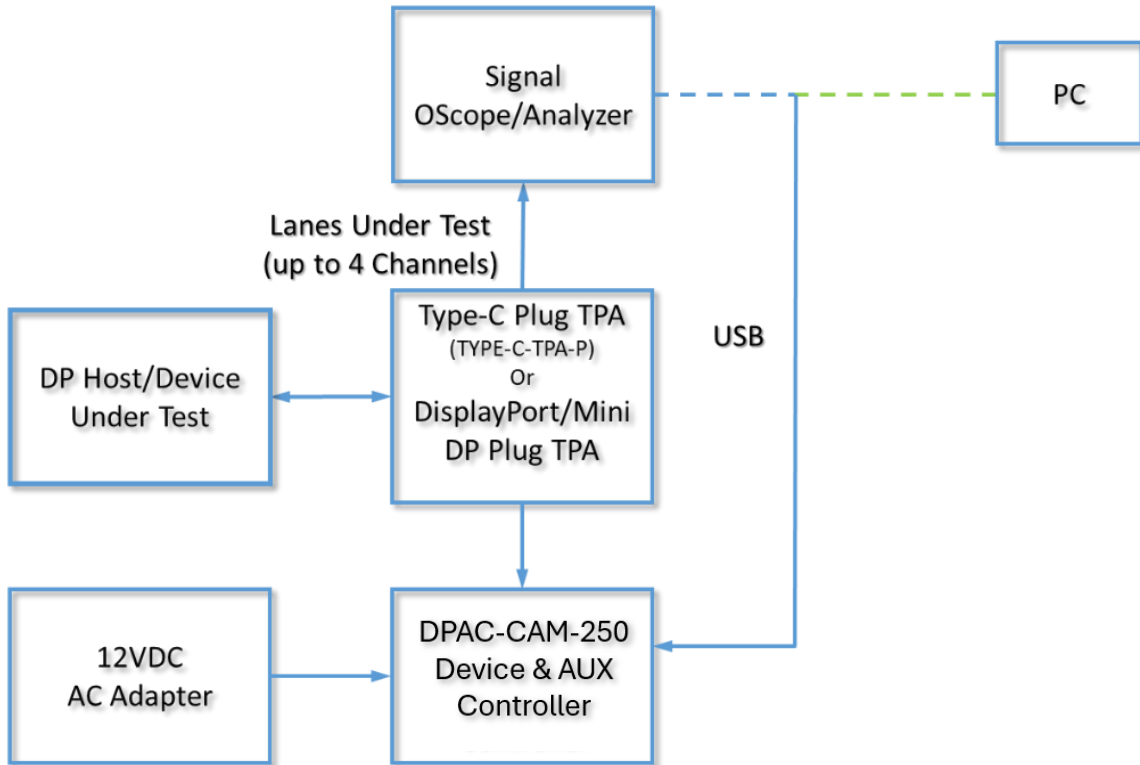

This third example illustrates a USB Type-C Host/Device test using a DPAC-CAM-250 device and Type-C Plug TPA connected to a Signal Oscilloscope/Analyzer. The Type-C Plug TPA connections are made to the DPAC-CAM-250 device through the A8 cable, B8 cable, and 14-position low speed cable. Additionally, if LFPS from the DPAC-CAM-250 device is being used then the B11 cable connects to the LFPS+ SMA and the B10 cable connects to LFPS- SMA.

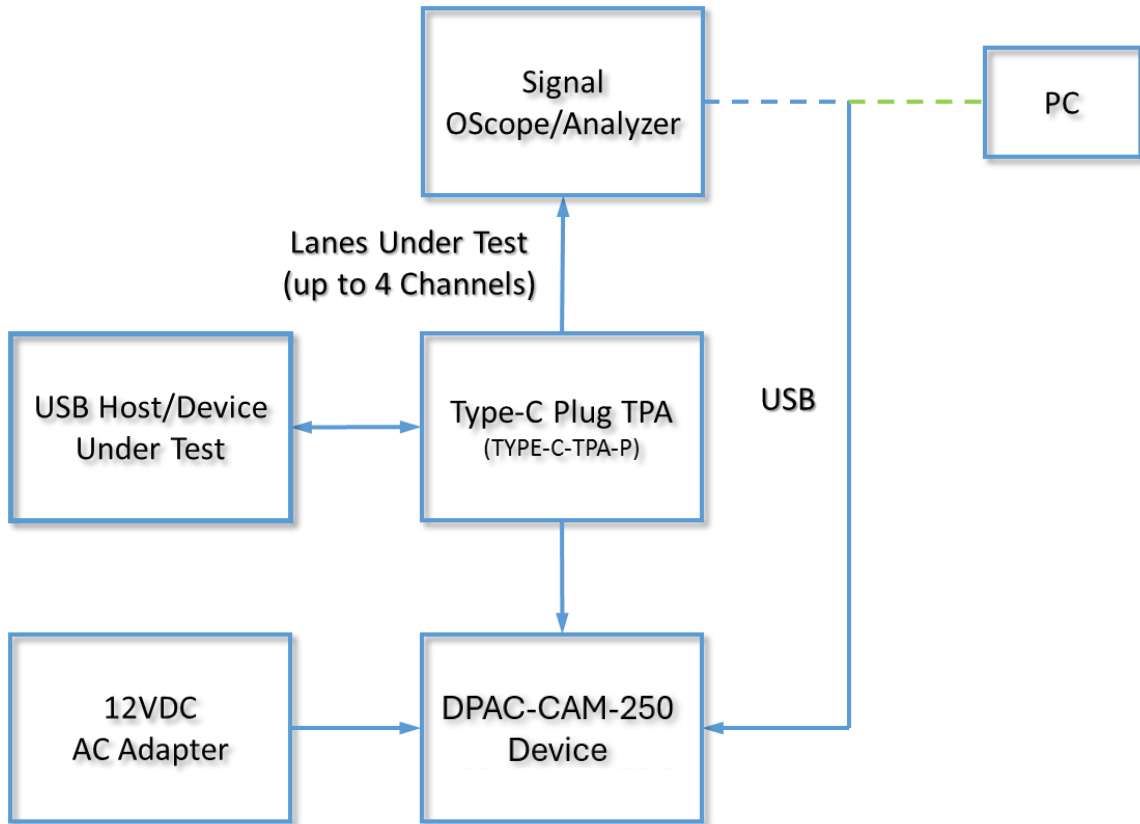

DPAC-CAM-250 User Interface Software

Introduction

The included User Interface (UI) and Application Program Interface (API) Software (SW) runs on a PC and operates the Wilder Technologies DPAC-CAM-250 device via a USB connection from a PC. The UI provides Screens that allow interaction with the DPAC-CAM-250 Hardware. The SW will run on most PCs with Windows 7, 8, 10, and 11. A powered USB port is required.

The UI makes calls to an API which directly operates the Hardware. The API is provided in a DLL file. Its calls are separately documented in this document.

This Manual is for UI Software Version 1.34, API Version 1.33, Firmware Version 1.18, and DPRx Version 1.29. The Firmware is Field Upgradable.

DPAC-CAM-250 LED Status Indicators

The DPAC-CAM-250 LED Status Indicators can be viewed through the rectangular opening on the right side of the board assembly.

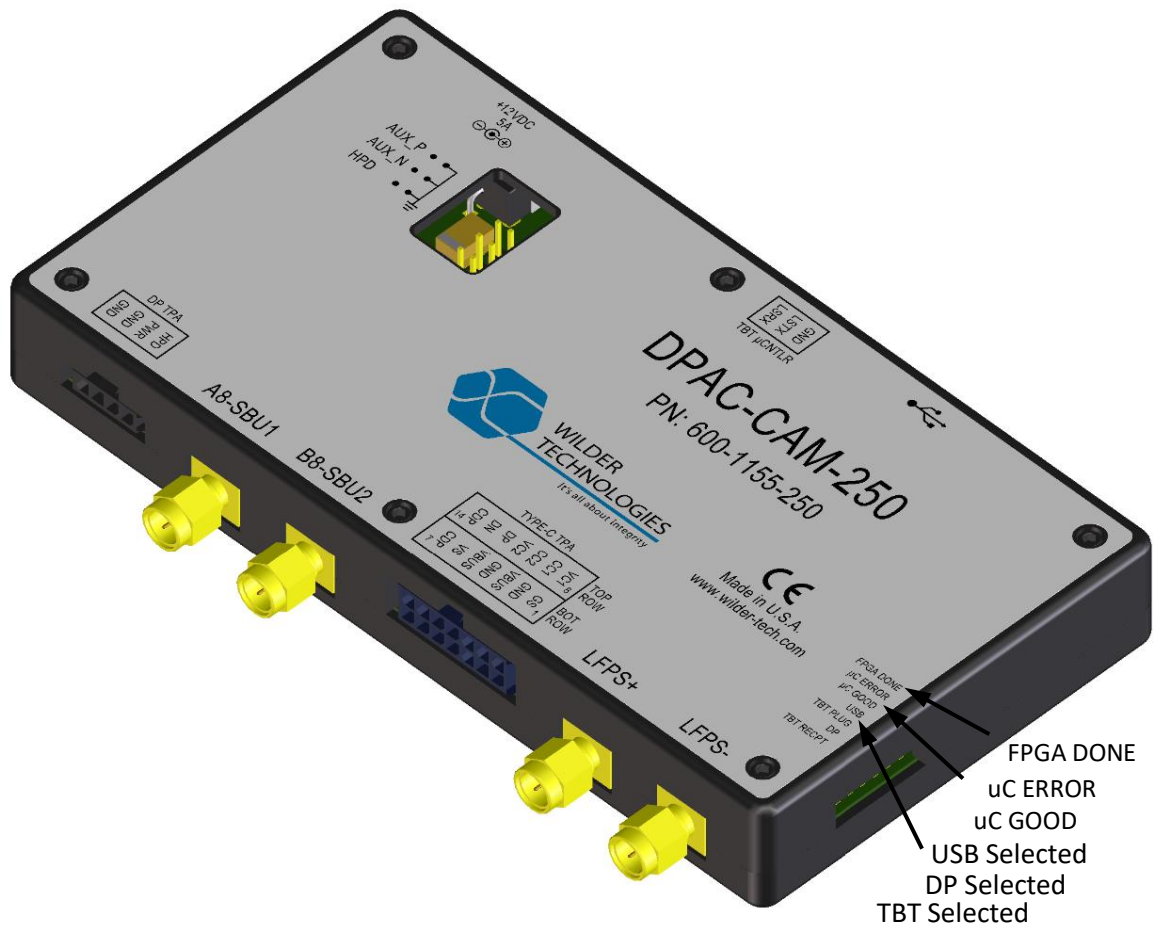

Figure 5. DPAC-CAM-250 LED Status Indicators

LED Indicator	Reference Designator	LED States
FPGA DONE	D25	Indicates FPGA Image has loaded and DPRx is ready
uC ERROR	D22	Will light up red when processor error occurred
uC GOOD	D8	Blinks when processor is running
USB	D9	On when USB configuration is selected
TBT PLUG	D10	On when Thunderbolt configuration is selected
DP	D11	On when DisplayPort configuration is selected
TBT RECPT	D12	Unused

DPAC-CAM-250 Device Supported USB Type-C Functions

The DPAC-CAM-250 device can be selected to operate in one of three different Modes. The Modes are implemented by the TI Type-C controller configuration ROMs.

Mode (Alt-Mode)	Data Role	Power Role	CC Current Advertised Power	PD Message Advertised Power
USB Native	DFP	Source	5V @ 3A	5V @ 3A
Thunderbolt	DFP	Source	5V @ 3A	5V @ 3A; 12V @ 3A
DisplayPort	UFP	Sink		

The DPAC-CAM-250 device Type-C controller has two selectable Data Roles:

DUT Type	Result
Device / Sink	Type-C Controller is Enabled and its Data Role is as configured by the Configuration ROM.
Host / Source	Type-C Controller is Turned Off. It does not act as a Host or Device. However certain Hosts can be Lane Flipped (see below).

The DPAC-CAM-250 device can Lane Flip the Super Speed Lanes in certain configurations:

DPAC-CAM-250 Device (Alt-Mode)	Lane Flip Capability
USB Native	Host or Device can be Lane Flipped
Thunderbolt	Host or Device can be Lane Flipped
DisplayPort	Host only can be Lane Flipped

The DPAC-CAM-250 device is connected to the Type-C DUT using the Type-C Plug TPA.

One of three Port Lane Flip Configurations may be selected:

Port Configuration	CC State at the Type-C Plug	SS Lane
Disconnected	CC1 and CC2 are disconnected	
Upside-Up (Un-Flipped)	CC1 is connected and CC2 is disconnected	0
Upside-Down (Flipped)	CC2 is connected and CC1 is disconnected	1

The connected CC1 line creates a path for current to be supplied to the DUT which then should Flip or Un-Flip. Note that because the Type-C TPA can be connected to the DUT physically, Flipped or Un-Flipped, the Configurations in the table may also be Flipped.

All selections are made via the API or User Interface Software.

DPAC-CAM-250 Software File List

These files are included in the Flash Drive.

Wilder_DPAC-CAM.exe	The Wilder DPAC-CAM UI Executable
Wilder_Type_C_Cap_A_API.dll	The Wilder DPAC-CAM/TBTCAM API Dynamic Link Library
910-0058-000 Rev C.pdf	DPAC-CAM-250 Device User Manual
910-0058-100 Rev D.pdf	DPAC-CAM-250 API Listing

Installation

The SW will run on Windows 7, 8, 10, and 11. Microsoft .NET Version 4.5 or greater is required. Some Windows 7 computers do not have this version. It may be downloaded from the Microsoft web site. If .NET is earlier than 4.5 there may be a message reporting that .NET is too old or an Error Message that includes the text "IAsyncState".

Copy the software distribution files to a folder on the PC from which the DPAC-CAM-250 UI Software and API DLL will be run. The .exe and .dll files should remain in this folder, but all other files can be moved.

Run the `Wilder_DUTC.exe` program. The start screen should report that its version is **1.34** or later. The Log Box should report that the API version is **1.33** or later.

DPAC-CAM-250 UI PC Program Operation

The UI Screen comes up when `Wilder_DPAC-CAM.exe` is run. Version information and several buttons will appear. Information, Status and Errors will appear in the Log Box. Errors are listed under each UI function description. Status and Errors are more thoroughly described further in this section.

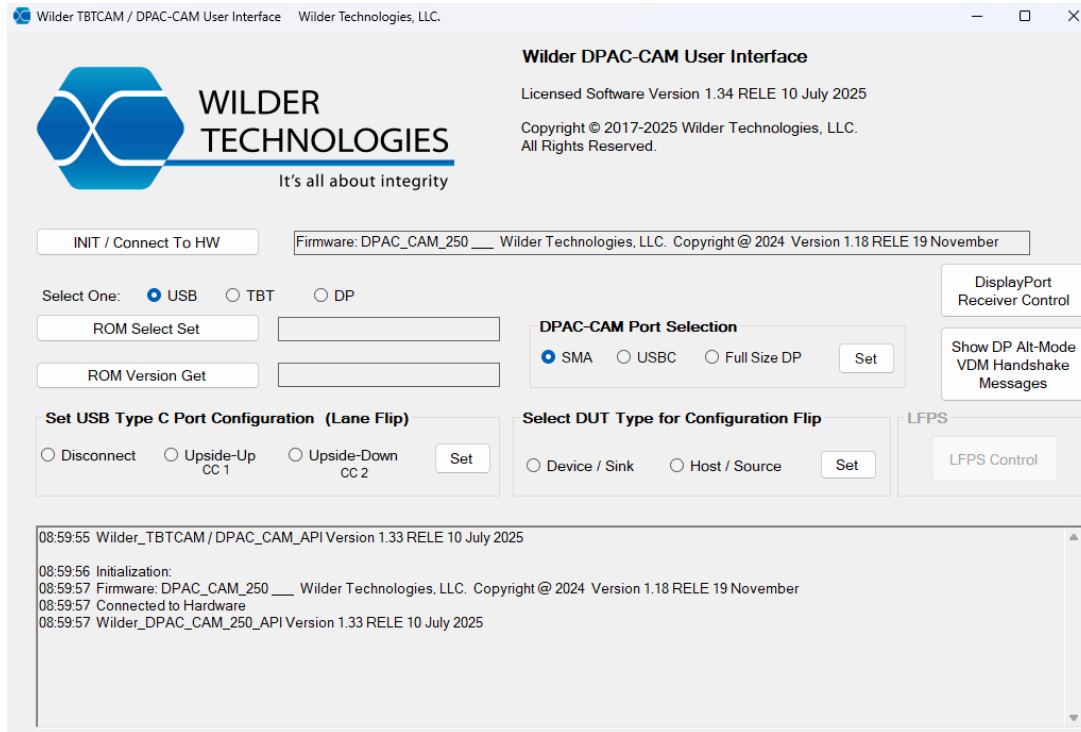

Figure 6. DPAC-CAM-250 UI Main Screen

DPAC-CAM-250 UI / API Connection to DPAC-CAM-250 Hardware

To operate both the UI and Hardware (HW) together, the UI SW (via the API) must connect to the DPAC-CAM-250 Device Hardware.

- Connect the HW to the 12 Volt power supply.
- Connect the HW to a PC Powered USB Port.
- Select the [INIT / Connect to HW] Button on the UI Screen. (The API `Init()` is called.)
- If successful, the Text Box to the right of the Connect Button updates to indicate connection to the HW and reports the Firmware Version. Verify that the version text is similar to:
 "Firmware: DPAC_CAM_250 ___ Wilder Technologies, LLC.
 Copyright @ 2024 Version 1.18 RELE 19 November"

The USB Configuration ROM is select by default when the DPAC-CAM-250 device HW is powered up.

These errors may be reported:

HANDLE_NOT_OBTAINED	The DPAC-CAM-250 HW is not connected to the PC
NO_HID_DEVICES_FOUND	The USB HID driver is not installed on the PC

If the UI Software session is exited the DPAC-CAM-250 device hardware will retain its state.

DPAC-CAM-250 Device TI Type-C Configuration ROM Select

The UI ROM is selected by Default when the DPAC-CAM-250 device HW is powered up.

To change the ROM (and therefore the Type-C Controller configuration):

Select one of the Radio Buttons [USB], [TBT], or [DP].

Select the [ROM Select Set] Button.

The selected ROM will be connected to the Type-C Controller and the Controller will be rebooted. This may take up to 500ms.

The API `ROM_Select_Set ()` is called.

These errors may be reported:

INIT_FAILURE	Initialization/Connection not performed or failed
POWER_MISSING	The 12 Volt Power is not connected
I2C_FAILURE	12 Volt Power and USB may not have been connected in correct sequence
ROM_INVALID	The Configuration ROM is missing or has a Bad Checksum

Select the [ROM Version Get] Button to obtain the version of the Configuration ROM.

Set USB Type-C Port Configuration (Lane Flip)

To change the Type-C Port Configuration (and Lane Flip), select one of the Radio Buttons [Disconnect], [Upside-Up], or [Upside-Down].

Select the [Set] Button.

The state of the CC lines is changed.

The API `USB_Port_Config_Set ()` is called.

These errors may be reported:

INIT_FAILURE	Initialization/Connection not performed or failed
POWER_MISSING	The 12 Volt Power is not connected
I2C_FAILURE	12 Volt Power and USB may not have been connected in correct sequence

Select DUT Type for Configuration Flip

To choose the DUT Type for Configuration Flip, select one of the Radio Buttons [Device / Sink], or [Host / Source].

Select the [Set] Button.

The Type-C Controller is Enabled with the selected Configuration ROM or Disabled.

The API `USB_Data_Role_Set ()` is called.

These errors may be reported:

INIT_FAILURE	Initialization/Connection not performed or failed
POWER_MISSING	The 12 Volt Power is not connected
I2C_FAILURE	12 Volt Power and USB may not have been connected in correct sequence

LFPS Pinging (USB Only)

When testing USB, the DPAC-CAM-250 device can send LFPS pings to cycle through USB compliance patterns. This option will become available after the USB ROM is selected. The default value is 3 cycles, but 2 or 4 cycles may be selected instead. The DPAC-CAM-250 device will send the selected number of cycles once the [Send LFPS Ping] button is pressed.

DisplayPort Handshake Messages (DisplayPort Alt Mode Only)

To see the content of a few DisplayPort Alt-Mode VDM handshake messages select the [Show DP Alt-Mode VDM Handshake Messages] Button.

The API `DP_Selected_Messages_Request ()` is called.

The following is displayed on the Log Box:

DP Alt Mode VDM Handshake Message Content:

DP Status Tx: No Connection
 DP Status Rx: No Connection
 DP Status Tx: 0x0000 (Outgoing DP Status Message)
 DP Status Rx: 0x0000 (Most Recent DP Status Message Received)
 DP Configure: 0x0000 (DP Configure Message)
 DP Discover: 0x0000 (DP Discovered Capabilities)

The content is only valid after a DP Alt-Mode handshake has started and it may change as the handshake is completed or failed.

The content is decoded in “VESA DisplayPort Alt Mode on USB Type-C Standard” Version 1.0b.

`u_DP_Status_Tx`: Current Outgoing DP Status message contents (Table 5-3)

`u_DP_Status_Rx`: Most recently received DP Status message contents (Table 5-3)

`u_DP_Configure`: DP Configure message when sent (DFP_U) or received (UFP_U) (Table 5-5)

`u_DP_Discover`: DP Discover Mode response when received (DFP_U) or sent (UFP_U) (Table 5-2)

DisplayPort Receiver (DPRx) Control

The DPAC-CAM-250 device can be used as a DisplayPort reference sink to test compliance patterns of a DisplayPort Source DUT. These options can be accessed via the [DisplayPort Receiver Control] button on the main screen. Once this button is pressed the DisplayPort Receiver Control window will appear as below:

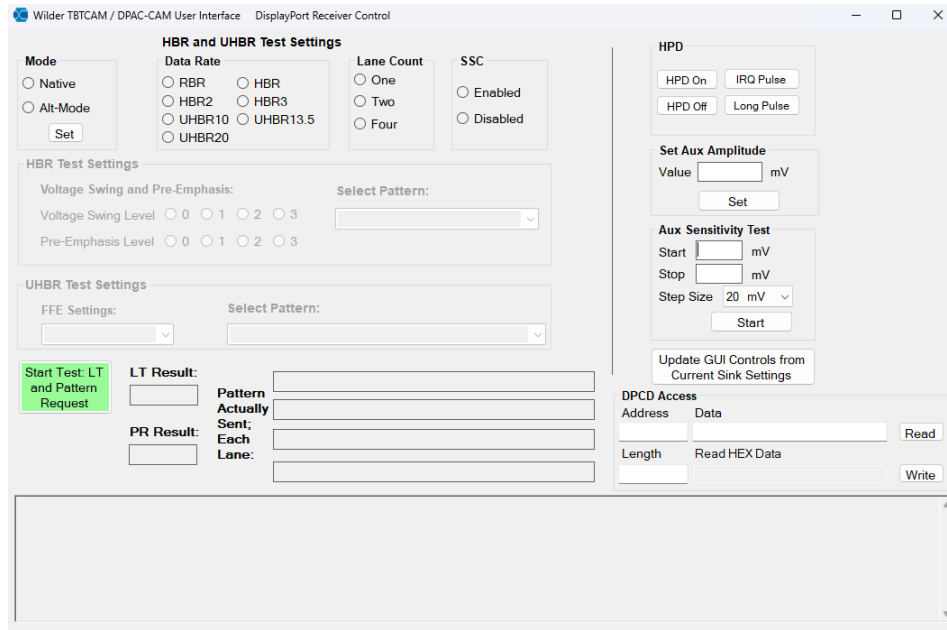

Figure 7. DisplayPort Receiver Control Screen

The Mode box allows the DPAC-CAM-250 device to be configured to be used with a USB Type-C DUT (DisplayPort Alt Mode) by selecting the Alt radio button, or with a native DisplayPort or Mini DisplayPort DUT by selecting the Native radio button then clicking the [Set] button.

HPD can be set high by selecting the [HPD On] button or set low by selecting the [HPD Off] button. Additional, an HPD IRQ pulse or long HPD pulse can be sent using the [IRQ Pulse] or the [Long Pulse] buttons respectively.

To initiate a PHY compliance pattern, the desired Data Rate, Lane Count, SSC setting, Voltage and Pre-Emphasis for RBR and HBR testing or FFE Setting for UHBR testing, and Pattern settings should be selected using their related controls on the screen then the [Start Test: LT and Pattern Request] button should be pressed. At this point, the DPAC-CAM-250 device will negotiate with DUT to set up the compliance pattern. This process usually takes between 10 to 15 seconds.

In addition to these controls, the DPCD registers can be read and written to manually using the DPCD Access box. The Address textbox is the desired DPCD register to be accessed, the Length textbox is how many register to be read or written to consecutively starting from the register given by the address textbox. When writing to DPCD registers, the Data textbox should be filled with the data to be written to the DPCD registers and separating each data entry by a comma. When reading, the data read from the DPCD registers will be displayed here.

The amplitude of the DisplayPort Receiver in the DPAC-CAM-250 can also be modified in this screen. To change the amplitude of the AUX signal from the DPRx, the desired value between 0 to 1640 should be written to the Value textbox under Set Aux Amplitude and then the [Set] button

should be pressed. Additionally, an AUX amplitude sensitivity test can be performed on DUT using the controls in the Aux Sensitivity Test box. In this mode, the DPAC-CAM-250 will try to communicate with the DUT at a given AUX amplitude and determine if the DUT correctly responds to the AUX signal at this amplitude. It will then step the amplitude of the AUX signal down by the value selected in the Step Size setting and repeat the test. This will continue until the stopped value is reached or the test fails and the DUT no longer is able to correctly recognize the AUX signal.

DPAC-CAM-250 Application Program Interface (API)

Please refer to the DPAC-CAM-250 API Listing for more information on the DPAC-CAM-250 application program interface.

Wilder Technologies, LLC – Limited Warranty

Wilder Technologies, LLC warrants that each Test Adapter, 1) is free from defects in materials and workmanship and, 2) conforms to Wilder Technologies specifications for a period of 12 months, with the exceptions of the Intel-Based TBTCI and TBTCAM Test Adapters, whereby are warranted for a period of 6 months, all other aspects of the Wilder Technologies, LLC warranty apply.

See Consumable and Fragile Material Warranty for exceptions to the 12-month warranty

The warranty period for a Test Adapter is a specified, fixed period commencing on the date of ship from Wilder Technologies, LLC. If you did not purchase your Test Adapter directly from Wilder Technologies, LLC, the serial number and a valid proof of purchase will be required to establish your purchase date. If you do not have a valid proof of purchase, the warranty period will be measured from the date of ship from Wilder Technologies, LLC.

If, during the warranty period, the Test Adapter is not in good working order, Wilder Technologies, LLC will, at its option, repair or replace it at no additional charge, except as is set forth below. In some cases, the replacement Test Adapter may not be new and may have been previously installed. Regardless of the Test Adapter's production status, Wilder Technologies, LLC appropriate warranty terms apply.

Consumable and Fragile Material Warranty

Wilder Technologies, LLC warrants that consumable materials and all fragile materials supplied by Wilder Technologies, LLC either as part of an instrument or system, or supplied separately, will be free from defects in material and workmanship at the time of shipment.

Extent of Warranty

The warranty does not cover the repair or exchange of a Test Adapter resulting from misuse, accident, modification, unsuitable physical or operating environment, improper maintenance by you, or failure caused by a product for which Wilder Technologies, LLC is not responsible. The warranty is voided by removal or alteration of Test Adapter or parts identification labels. The initial three months are unconditional; the remaining months excludes plugs, receptacles and SMA connectors. Connectors are wear items and excluded from the warranty after the initial three months.

These warranties are your exclusive warranties and replace all other warranties or conditions, express or implied, including but not limited to, the implied warranties or conditions of merchantability and fitness for a particular purpose. These warranties give you specific legal rights and you may also have other rights which vary from jurisdiction to jurisdiction. Some jurisdictions do not allow the exclusion or limitation of express or implied warranties, so the above exclusion or limitation may not apply to you. In that event, such warranties are limited in duration to the warranty period. No warranties apply after that period.

Items Not Covered by Warranty

Wilder Technologies, LLC does not warrant uninterrupted or error-free operation of a Test Adapter.

Any technical or other support provided for a Test Adapter under warranty, such as assistance via telephone with "how-to" questions and those regarding Test Adapter set-up and installation, will be provided **WITHOUT WARRANTIES OF ANY KIND**.

Warranty Service

Warranty service may be obtained from Wilder Technologies, LLC by returning a Wilder Technologies, LLC Returns Material Authorization and the Test Adapter to Wilder Technologies, LLC during the warranty period. To obtain RMA number, contact support@wilder-tech.com.

You may be required to present proof of purchase or other similar proof of warranty entitlement. You are responsible for any associated transportation charges, duties and insurance between you and Wilder Technologies, LLC. In all instances, you must ship Test Adapters in Wilder Technologies, LLC approved packaging. Information on packaging guidelines can be found at: www.wilder-tech.com. Wilder Technologies, LLC will ship repaired or replacement Test Adapter Delivery Duty Prepaid (DDP) and will pay for return shipment. You will receive title to the repaired or replacement Test Adapter and you will be the importer of record.

Wilder Technologies, LLC – Terms & Conditions of Sale

- 1. Other Documents:** This Agreement may NOT be altered, supplemented, or amended by the use of any other document(s) unless otherwise agreed to in a written agreement signed by both you and Wilder Technologies, LLC. If you do not receive an invoice or acknowledgement in the mail, via e-mail, or with your Product, information about your purchase may be obtained at support@wilder-tech.com or by contacting your sales representative.
- 2. Payment Terms, Orders, Quotes, Interest:** Terms of payment are within Wilder Technologies, LLC's sole discretion, and unless otherwise agreed to by Wilder Technologies, LLC, payment must be received by Wilder Technologies, LLC prior to Wilder Technologies, LLC's acceptance of an order. Payment for the products will be made by credit card, wire transfer, or some other prearranged payment method unless credit terms have been agreed to by Wilder Technologies, LLC. Invoices are due and payable within the time period noted on your invoice, measured from the date of the invoice. Wilder Technologies, LLC may invoice parts of an order separately. Your order is subject to cancellation by Wilder Technologies, LLC, in Wilder Technologies, LLC's sole discretion. Unless you and Wilder Technologies, LLC have agreed to a different discount, Wilder Technologies, LLC's standard pricing policy for Wilder Technologies, LLC-branded systems, which includes hardware, software and services in one discounted price, allocates the discount off list price applicable to the service portion of the system to be equal to the overall calculated percentage discount off list price on the entire system. Wilder Technologies, LLC is not responsible for pricing, typographical, or other errors in any offer by Wilder Technologies, LLC and reserves the right to cancel any orders resulting from such errors.
- 3. Shipping Charges; Taxes; Title; Risk of Loss:** Shipping, handling, duties and tariffs are additional unless otherwise expressly indicated at the time of sale. Title to products passes from Wilder Technologies, LLC to Customer on shipment from Wilder Technologies, LLC's facility. Loss or damage that occurs during shipping by a carrier selected by Wilder Technologies, LLC is Wilder Technologies, LLC's responsibility. Loss or damage that occurs during shipping by a carrier selected by you is your responsibility. You must notify Wilder Technologies, LLC within 7 days of the date of your invoice or acknowledgement if you believe any part of your purchase is missing, wrong or damaged. Unless you provide Wilder Technologies, LLC with a valid and correct tax exemption certificate applicable to your purchase of Product and the Product ship-to location, you are responsible for sales and other taxes associated with the order. **Shipping dates are estimates only.**
- 4. WARRANTY:** WILDER TECHNOLOGIES, LLC, warrants that the item(s) manufactured under the Buyer's contract shall be free from defects in materials and workmanship furnished by WILDER TECHNOLOGIES, LLC, and shall conform to the applicable drawings and specifications. WILDER TECHNOLOGIES, LLC'S liability herein, for breach of warranty, contract or negligence in manufacturing, shall be limited to repair or replacement. Repair or replacement of defective items will be applicable only if the Buyer notifies WILDER TECHNOLOGIES, LLC, by written notice within 30-days of delivery. All claims shall be addressed to: support@wilder-tech.com or WILDER TECHNOLOGIES, LLC, 6101A East 18th Street, Vancouver, Washington 98661 U.S.A.; ATTENTION: Customer Service Manager. WILDER TECHNOLOGIES, LLC, reserves the right to inspect at the Buyer's plant all items claimed to be defective or nonconforming prior to authorizing their return. WILDER TECHNOLOGIES, LLC, assumes no liability for the results of the use of its components in conjunction with other electric, electronic or mechanical components, circuits and/or systems. The foregoing constitutes the sole and exclusive remedy of the Buyer and the exclusive liability of WILDER TECHNOLOGIES, LLC, and is IN LIEU OF ANY AND ALL OTHER WARRANTIES, STATUTORY, IMPLIED OR EXPRESSED AS TO MERCHANTABILITY, FITNESS FOR THE PURPOSE SOLD, DESCRIPTION, QUALITY, and PRODUCTIVENESS OR ANY OTHER MATTER. Without limiting the foregoing, in no event shall WILDER TECHNOLOGIES, LLC, be liable for loss of use, profit or other collateral, or for special and/or consequential damages.
- 5. RETURNED GOODS:** WILDER TECHNOLOGIES, LLC, will accept only those goods for return that have been authorized for return. All goods authorized for return shall be assigned a Returned Material Authorization (RMA) Number. The RMA Number shall be clearly marked on the shipping container(s) and all documentation accompanying the goods authorized for return. The RMA Number shall be assigned by WILDER TECHNOLOGIES, LLC pursuant to the conditions set forth in Paragraph 4, WARRANTY.
- 6. UNITED STATES GOVERNMENT CONTRACTS:** In the event this offer is accepted under Government contract, WILDER TECHNOLOGIES, LLC, agrees to accept clauses required by Government regulations and to waive WILDER TECHNOLOGIES, LLC conditions inconsistent therewith. WILDER TECHNOLOGIES, LLC, certifies that it is a regular manufacturer or dealer of the goods and/or services offered herein and that the prices offered do not exceed those charged to any customer for like quantities, services or materials under the same conditions.

Compliance with Environmental Legislation

Wilder Technologies, LLC, is dedicated to complying with the requirements of all applicable environmental legislation and regulations, including appropriate recycling and/or disposal of our products.



WEEE Compliance Statement

The European Union adopted Directive 2002/96/EC on Waste Electrical and Electronic Equipment (WEEE), with requirements that went into effect August 13, 2005. WEEE is intended to reduce the disposal of waste from electrical and electronic equipment by establishing guidelines for prevention, reuse, recycling and recovery.

Wilder Technologies has practices and processes in place to conform to the requirements in this important Directive.

In support of our environmental goals, effective January 1st, 2009 Wilder Technologies, LLC has partnered with EG Metals Inc. – Metal and Electronics Recycling of Hillsboro, Oregon, www.egmetalrecycling.com, to recycle our obsolete and electronic waste in accordance with the European Union Directive 2002/96/EC on waste electrical and electronic equipment ("WEEE Directive").

As a service to our customers, Wilder Technologies is also available for managing the proper recycling and/or disposal of all Wilder Technologies products that have reached the end of their useful life. For further information and return instructions, contact support@wilder-tech.com.



Compliance to RoHS 2 Substance Restrictions

Wilder Technologies, LLC certifies that the parts described in this document are compliant to the substance restrictions of Directive 2011/65/EU of the European Parliament, and of the Council of 8 June, 2011 on the restriction of the use of certain hazardous substances in electrical and electronic equipment (RoHS 2 Directive), prohibiting the use in homogeneous materials in excess of the listed maximum concentration value, except in cases where use is allowed by applicable exemptions listed in Annex III and Annex IV of the Directive.

Compliance with RoHS 2 has been verified through internal controls at design and production sites, including establishment of processes for specifying and controlling materials and segregation of non-compliant parts, receipt of supplier declarations of compliance and/or analytical test.

Glossary of Terms

TERMINOLOGY	DEFINITION
Alt Mode (Alternate Mode)	Operation defined by a vendor or standards organization that is associated with a SVID assigned by the USB-IF. Entry and exit into and from an Alternate Mode is controlled by <i>USB PD r2.0 v1.1</i> Structured VDM Enter Mode and Exit Mode commands.
API	Application Program Interface
Captive Cable (Tethered)	Cable that is terminated on one end with a USB Type-C plug and has a vendor-specific means with which to connect (hard-wired or custom detachable) on the opposite end.
CC	Configuration Channel
DFP	Downward Facing Port
DLL	Dynamic Link Library (an API is usually inside)
DP	DisplayPort
DPRx	DisplayPort Receiver
DUT	Device Under Test
Far-End Crosstalk or FEXT	Crosstalk that is propagated in a disturbed channel in the same direction as the propagation of a signal in the aggressor channel. The terminals of the aggressor channel and the victim channel are usually close to each other.
Informative	The designation of a test that is not required for compliance but is considered important from a characterization standpoint. It is provided for informational purposes only.
Initiator	Port that initiates a <i>USB PD r2.0 v1.1</i> Vendor-Defined Message. It is independent of the port's PD role (e.g., Provider, Consumer, Provider/Consumer, or Consumer/Provider).
Insertion loss	The ratio, expressed in dB, of incident power to delivered power.
MOI	Method of implementation.
Near-End Crosstalk or NEXT	Crosstalk that is propagated in a disturbed channel in the opposite direction as the propagation of a signal in the aggressor channel. The terminals of the aggressor channel and the victim channel are usually close to each other.
Normative	The designation of a test that is required for compliance.
Physical Link	Two differential signal pairs, one pair in each direction, that connect two physical phys.
Responder	Port that responds to the Initiator of a <i>USB PD r2.0 v1.1</i> Vendor-Defined Message. Independent of the port's PD role (e.g., Provider, Consumer, Provider/Consumer, or Consumer/Provider).
Return Loss	The ratio, expressed in dB, of incident power to reflected power.
SBU	Sideband Use.
TBT	Thunderbolt
UPF	Upward Facing Port
USB Type-C	Generic reference to a USB Type-C Plug, USB Type-C Port, USB Type-C Receptacle, or USB Type-C Cable Assembly, as specified in <i>USB Type-C r1.1</i> .
VCONN-Powered	VCONN is a 5V, 1W power supply used to power the IC within an electronically marked Type-C cable. The DFP will supply the VCONN power upon start-up
VDM	Vendor Defined Messages (subset of PD messages on the CC lines)

Index

- 3-Position Low-Speed Connector, 10
- Cable Bend Limits, 6
- Cable Tension (Pull Forces), 6
- Cable Twisting (Torque), 6
- Cleaning, 8
- Compliance
 - RoHS, 25
 - WEEE, 25
- Connections
 - SMA, 7
 - Type-C TPA to DUT, 6
- Data Roles, 16
- DisplayPort Handshake Messages, 20
- DisplayPort Type-C Compliance Specifications, 3
- DisplayPort Type-C Standard, 3
- DPAC-CAM-250 Device Application Program Interface (API), 22
- DPAC-CAM-250 Device Pinout, 10
- DPAC-CAM-250 Device Supported USB Type-C Functions, 16
- DPAC-CAM-250 Device User Interface Software, 15
- DPAC-CAM-250 Included Items, 4
- DPAC-CAM-250 Software File List, 17
- DPAC-CAM-250 TI Type-C Configuration ROM Select, 19
- DPAC-CAM-250 UI / API Connection, 18
- DPAC-CAM-250 UI PC Program Operation, 18
- Electrostatic Discharge Information (ESD), 9
- ESD protection, 9
- Figures
 - DisplayPort Receiver Control Screen, 21
 - DPAC-CAM-250 Device Connectors, 10
 - DPAC-CAM-250 Device LED Status Indicators, 15
 - DPAC-CAM-250 UI Screen, 18
 - The DPAC-CAM-250, 4
 - The DPAC-CAM-250, 3
- Flash Drive, 17
- Glossary, 26
- Handling and Storage, 8
- Lane Flip Operation, 16, 19
- Making Connections, 8
- Mechanical and Environmental Specifications, 10
- Modes, 16
- Product Inspection, 5
- Product Return, 5
- Pull Force, 6, 7
- Secure Storage, 5
- Set DUT Type for Configuration Flip, 20
- Software Installation, 17
- Support, 24, 25
- Supporting Instrument Cables or Accessories, 7
- Tables
 - DisplayPort Low-Speed Connector Pin Assignments, 11
 - General Specifications, 10
 - Mini-USB Connector Pin Assignments, 11
 - Thunderbolt Microcontroller Connector, 11
 - Type-C Low-Speed Connector Pin Assignments, 11
- Terms and Conditions of Sale, 24
- Thunderbolt Type-C Compliance Specifications, 3
- Thunderbolt Type-C Standard, 3
- USB Type-C Compliance Specifications, 3
- USB Type-C Standard, 3
- User Models
 - DisplayPort Host/Device Testing, 13
 - Thunderbolt Host/Device Testing, 12
 - USB Host/Device Testing, 14
- Visual Inspection, 8
- Warranty, 23
- Web Sites
 - support@wilder-tech.com, 23, 24, 25
 - www.egmetalrecycling.com, 25
 - www.wilder-tech.com, 23

Visit our website at www.wilder-tech.com



Wilder Technologies, LLC
11201 NE 9th St.
Vancouver WA, 98684
Phone: 360-859-3041
Fax: 360-859-3105
www.wilder-tech.com

©2025 Wilder Technologies, LLC
Document No. 910-0058-000 Rev. C
Initial Release: 9/23/2019 Revised: 7/10/2025